

JB1113N

DISPENSE CONTROLLER

The JB1113N automatic liquid dispenser with its versatile design makes it perfectly suited for a wide variety of dispensing applications, from microdot deposits to large potting and filling. Suitable for all types of fluid, includes a suck-back feature to ensure low viscosity liquids do not drip.

The JB1113N provides timer programming from 0.01 to 31 seconds. Foot pedal initiation can be for either maintained or momentary operation.

All set up hoses and fittings, along with barrels and tips, make the unit ready to use right out of the box.



Standard Accessories

Qty	Description	Re-order P/N	Re-order Qty/Pkg
1	Power cord – 110V	560033-LF	1
1	Power cord – 220V	560033E-LF	1
1	Power cord – 220V	560033E-PLUG	1
1	Barrel stand	560751LF	1
1	Air input Line	561851	1
1	Foot pedal	560027D	1
1	30cc barrel adapter	5601468	1
1	5cc barrel adapter	5601035	1
3	30cc barrel	5601004	10
2	5cc barrel	5601001	10
3	30cc piston PE	5601465	20
2	5cc piston PE	5601019	40
1	Component Kit	DCK500	1

Specifications

• Size:	8 5/8" x 8 1/2" x 2 5/8" (22 x 21 x 6.7cm)
• Weight:	2.2 lbs. (1 kg)
• Input Voltage:	90-260 VAC
• Dispense Time:	0.01 - 31 seconds
• Internal Voltage	24 VDC
• Cycle Initiation:	Maintained or Momentary
• Cycle Speed:	600+ /Minut
• Air Input:	70-100psi (5-7 bar)
• Air Output:	1-100psi (0.1-7 bar)
• Standards:	European CE approved unit
• Barrel "Suck-Back" Feature	

SETTING UP

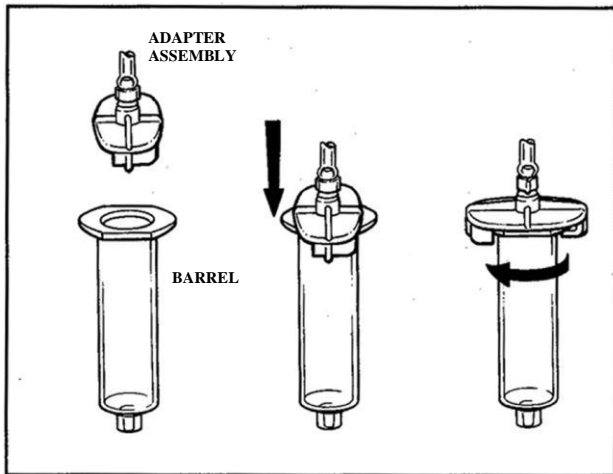

1. Connect air hose to filtered compressed air 70 - 100 psi (5-7 bar) and connect fitting to the dispenser.
2. Insert Foot Switch Plug.
3. Insert and twist male quick connect into dispenser.
4. Insert power cord female plug into dispenser and insert the male plug into a grounded outlet.
5. Fill barrel (with barrel tip cap on the barrel) with material to be dispensed and lock barrel to adapter assembly as shown in the image to the left.

AIR & ELECTRICAL SET UP DIAGRAM

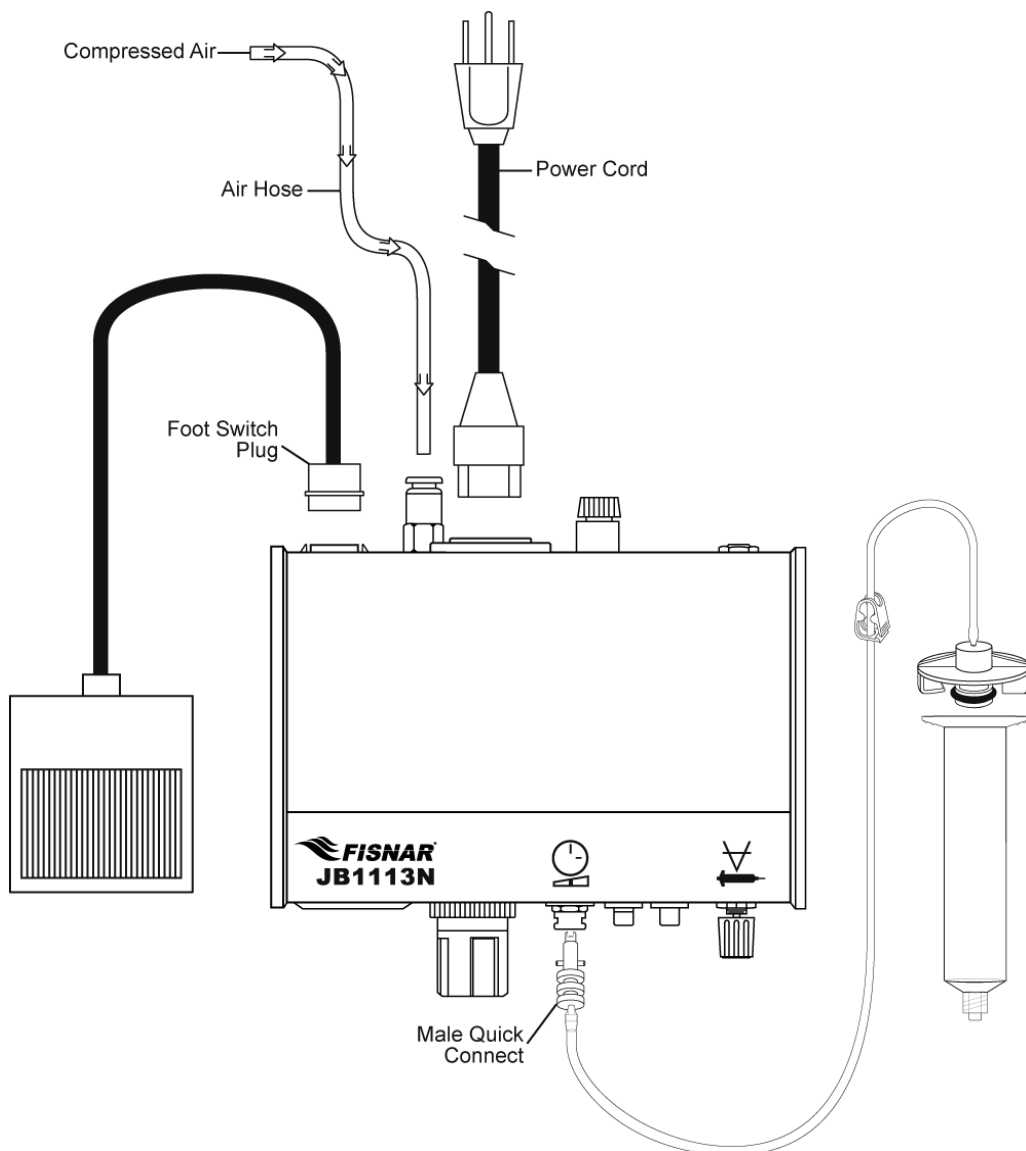

UNDERSTANDING THE CONTROLS

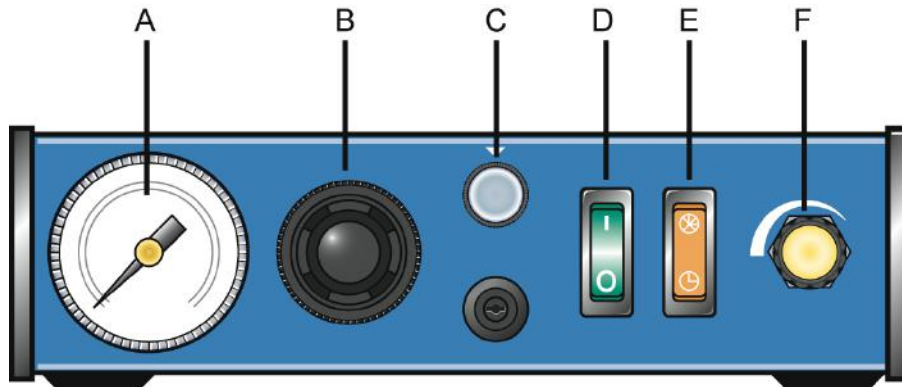

- A Pressure Gauge** - Displays the current pressure setting.
- B Pressure Regulator** - Sets the required pressure setting. Turn the knob clockwise to increase and counter-clockwise to decrease pressure as needed.
- C Timer Setting** - Sets the required time setting when Timer Mode is on. Please note that the numbers indicated on the knob are for reference only.
- D Power Switch** - Turns the unit on or off.
- E Timer Mode Switch** - Toggles between operator control mode (light on) and timer mode (light off)
- F Vacuum Control** - Turns on the vacuum.
- G Foot Pedal** - Actuates the dispenser controller.

Helpful Hints for making Deposits

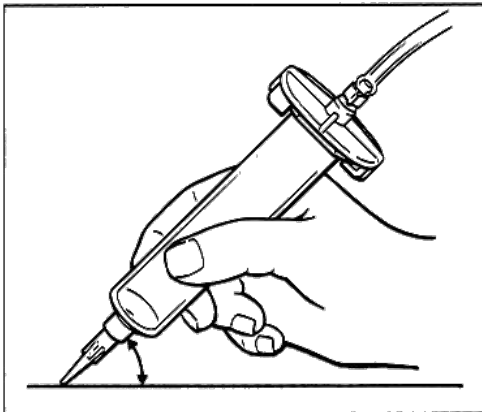

1. Hold the barrel at an approximately 60° ($\pm 20^\circ$) angle (Fig. 1).
2. Lift the tip as vertical as possible (Fig. 2) after making the deposit.
3. Do not let the liquid flow back into the controller (Fig. 3.)

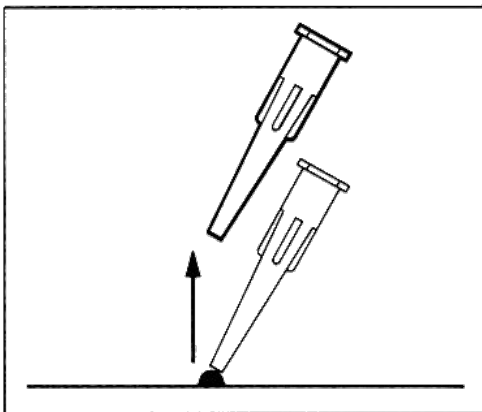
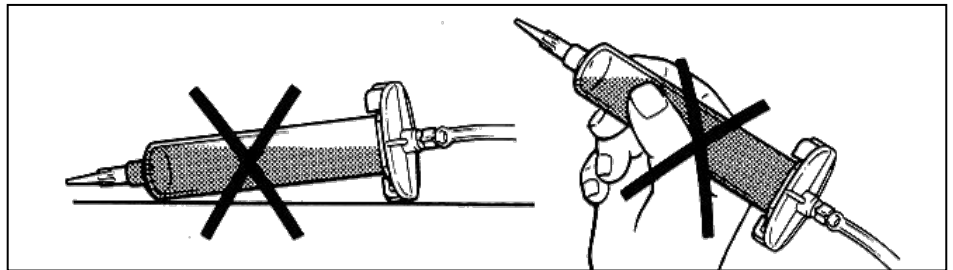

4. You may vary the shot size by doing one or a combination of the following:
 - Increasing or decreasing time only (C)
 - Increasing or decreasing pressure only (A) (B)
 - Increasing or decreasing size of tip
5. To increase pressure, turn the pressure regulator knob (B) clockwise and counter-clockwise to decrease it. When decreasing pressure, set the gauge first to less than the value desired and then just increase it as needed.
6. For thin liquids like water, you can prevent dripping by slowly turning the vacuum control (F) counter clockwise.

WARNING: Too much vacuum will cause air bubbles and suck liquid back into the controller thus creating permanent damage to the unit.

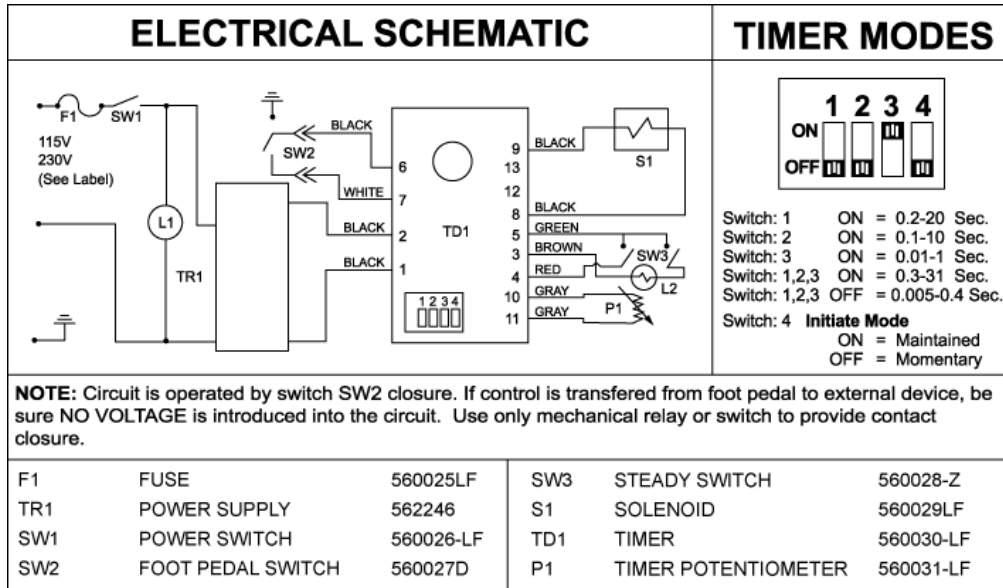

LIMITED WARRANTY

Manufacturer warrants this product to the original purchaser for a period of two (2) years from the date of purchase to be free from defects in material and workmanship, but not against damages caused by misuse, negligence, accident, faulty installation, abrasion, corrosion or by not operating in accordance with factory recommendations and instructions. Manufacturer will repair or replace (at factory's option), free of charge, any component of the equipment thus found to be defective, upon prepaid return of the equipment to the factory during the warranty period of the equipment. In no event shall any liability or obligation of Manufacturer arising from this warranty exceed the purchase price of the equipment. This warranty is valid only when 5 micron filtered air is used. The manufacturer's written liability, as stated herein, cannot be altered or enlarged except by a written statement signed by an officer of the company. In no event shall manufacturer be liable for consequential or incidental damages. A return authorization is required from FISNAR INC. prior to shipping a defective unit to the factory.

Manufacturer reserves the right to make engineering or product modifications without notice.

