

# SV2000N SPRAY VALVE OPERATING MANUAL



15 Corporate Drive, Suite E - Wayne - NJ 07470  
Tel: (973) 646-5044 E-mail: [info@fisnar.com](mailto:info@fisnar.com)  
[www.fisnar.com](http://www.fisnar.com)

This page is intentionally left blank.

## Contents

Chapter 1.	Introduction .....	4
Chapter 2.	Specifications .....	4
Chapter 3.	Explanation of Parts .....	5
Chapter 4.	Operating Principles .....	5
Chapter 5.	Operating Procedure .....	6
5-1.	Setup .....	7
5-2.	Maintenance .....	8
Chapter 6.	Dimensions.....	9
6-1	SV2001N .....	9
6-1	SV2002N .....	9
6-1	SV2003N .....	10

## Chapter 1. Introduction

The F2000N spray valve is designed as a Low Volume Low Pressure(LVLP) type. This valve can dispense material from low viscosity to high viscosity.

### **FEATURES:**

- Simple structure
- Long-time use
- Using diaphragm seal for high efficiency
- Prompt operation
- High quality

There are 3 types of SV2000N spray valves differentiated by spray pattern.

The fine dot and bead pattern (SV2001N), medium pattern (SV2002N), and the fan pattern (SV2003N). It is recommended that the SVC100 Spray valve controller is used with this valve to ensure a safe and precise dispense.

## Chapter 2. Specifications

Weight	8.8 oz (250 gm)
Operating Air Pressure	60 - 80 psi (4-6 bar)
Atomizing Air Pressure	1 - 30 psi
Fluid Viscosity Range	Up to 100 cps
Fluid Pressure	1 – 100 psi (0.1 – 7 bar) – <i>depending on material viscosity</i>
Spray Angle at 40mm	SV2001N - 20° SV2002N - 30° SV2003N - 37°
Spray Pattern	Circular (conical spray)
Sample spray path character	
SV2001N	min bead 3mm, overspray 0.5mm, z distance off 3mm, speed 50mm
SV2002N	min bead 12mm, overspray 5mm, z distance off 10mm, speed 50mm
SV2003N	min bead 18mm, overspray 10mm, z distance off 20mm, speed 50mm
Flow Rate	Up to 2.4 ℓ
Operating Frequency	Over 200 cycles/min.
Operating Air Inlet	M5 * P0.8 thread with push-in fitting for Ø4 Urethane hose (included)
Atomizing Air Inlet	M5 * P0.8 thread with push-in fitting for Ø4 Urethane hose (included)
Material Inlet	1/8 NPT

### Chapter 3. Explanation of Parts

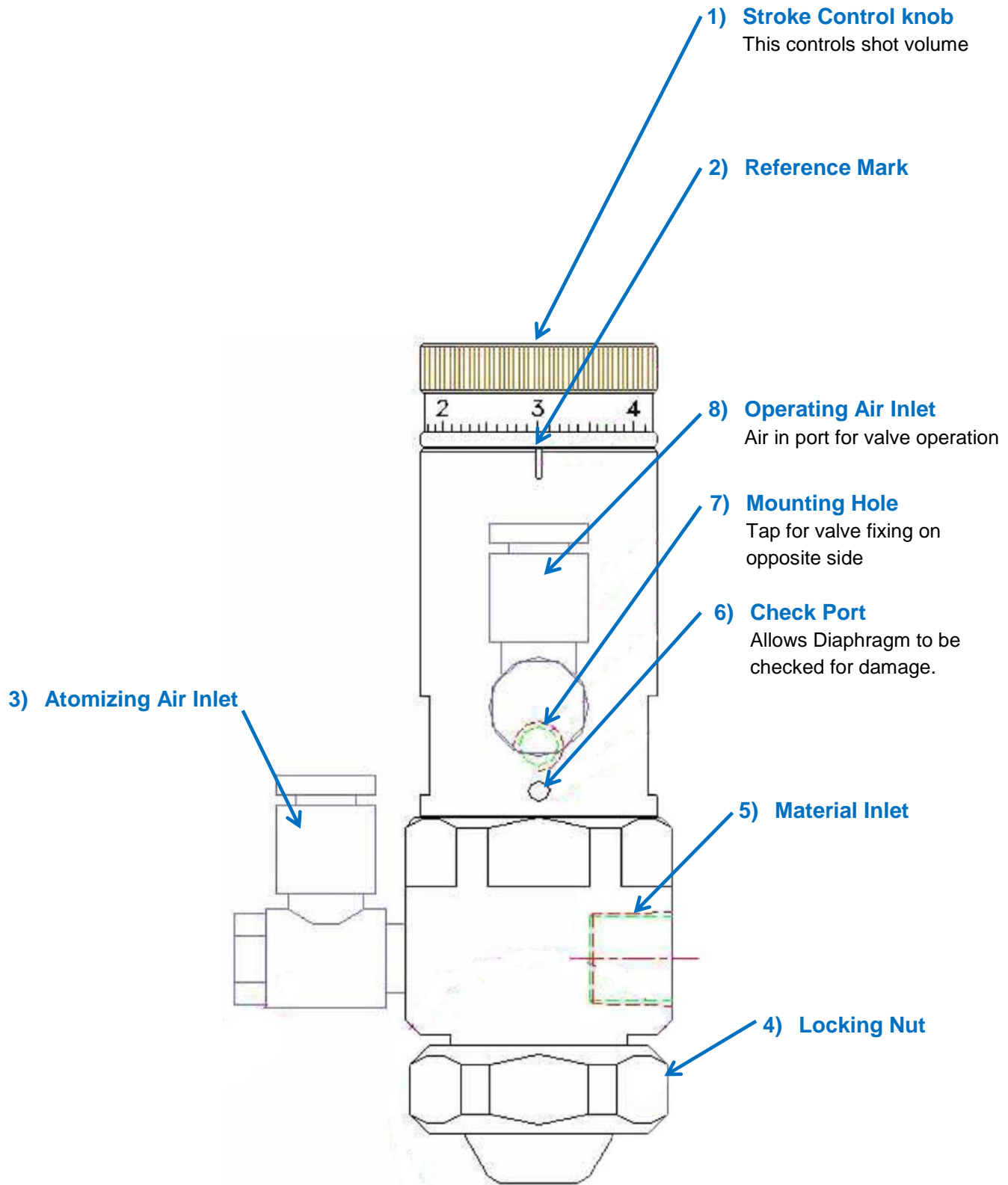

## Chapter 4. Operating Principles

The SV2000N can spray a very small volume of minute particles.

When air is added to the operating air inlet the piston moves up. The amount that the piston will move is controlled by the stroke control knob on the top of the valve. When the piston is in the up position the needle unseats itself from the valve seat and allows liquid to flow to the nozzle. At the same time pressurized air from the atomizing air inlet flows to the annulus. When the atomized air and the pressurized material meet it causes the material to spray.

When the operating air turns off the piston will move down by spring. This will cause the needle to become seated in the valve and material flow to stop. At the same time the atomized air flow is turned off.

The volume of material in the spray is controlled by the valve. The spraying width is controlled by the type of nozzle and the distance the valve is kept from the spray area.

**NOTE:** Applying a delay time will help in the prevention of material clumping at the end of the valve.

The SVC100 is designed for easy control of the delay time and regulating precise spray air pressure.

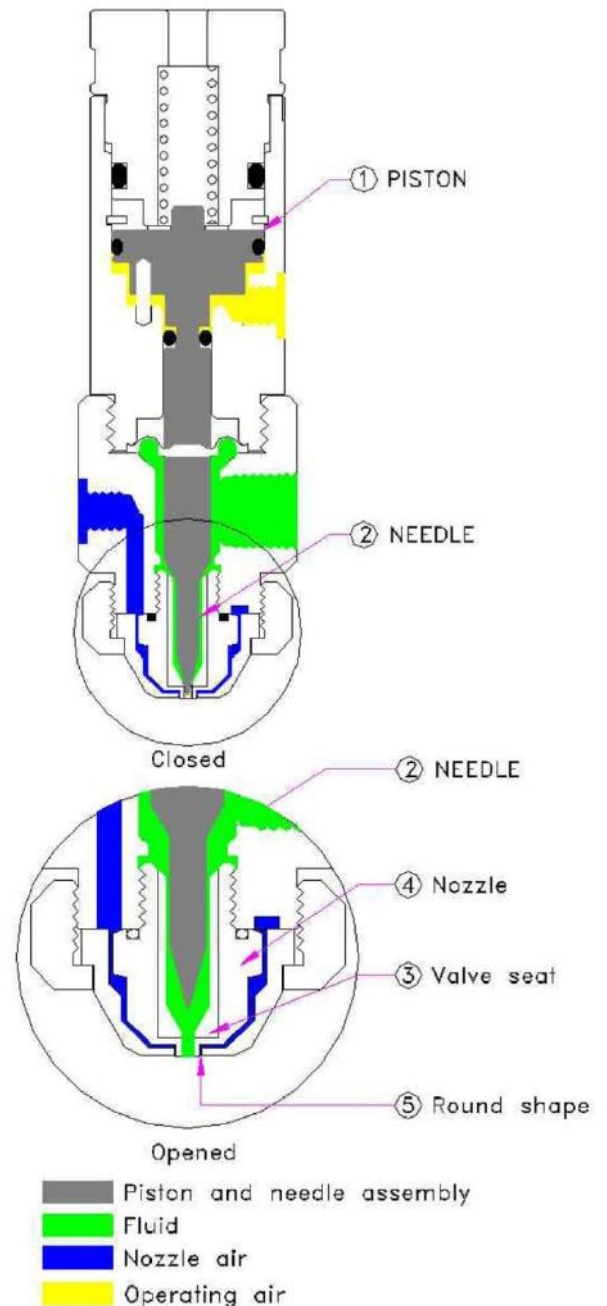

## Chapter 5. Operating Procedure

### 5-1. Setup

Example of general installation.

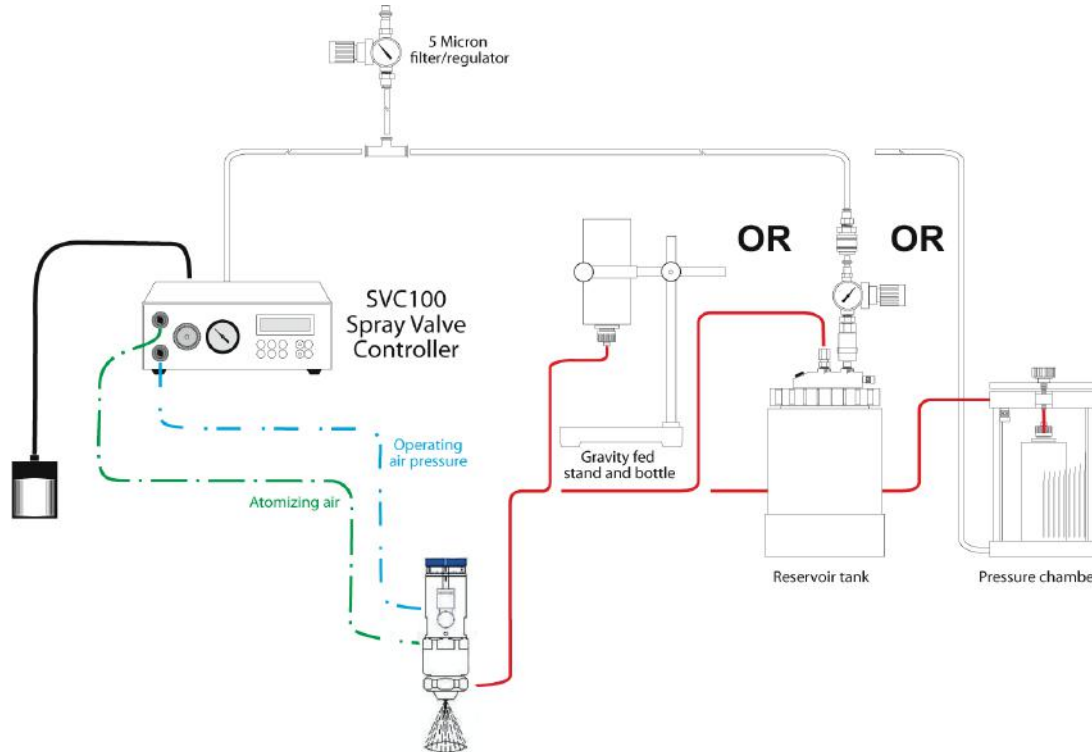

- 1) Before connecting any air or material lines to your valve be sure to consult all product manuals for your system separately referring to their safety guidelines and operating instructions.
- 2) Upon connection of all material and airlines set the stroke control knob to the desired location. (Note: If the stroke control knob is turned more than 2 rotations counter clockwise the valve will begin to leak as the needle will no longer be seated.)
- 3) After the valve operating air pressure and atomizing air pressure are set correctly try a steady continuous spray. This will help you to evaluate the valves current settings and refine them. Use the following chart to help you with the refinement process.

Problem		Solution
Spray Density	High	Reduce the shot volume. (Stroke control knob ↑, Time ↓, Tank pressure ↑)
	Low	Increase the shot volume. (Stroke control knob ↓, Time ↑, Tank pressure ↓)
Spray Particle	Large	Increase atomizing air pressure.
	Small	lower atomizing air pressure.
Spray Width	Large	Decrease the distance of spraying.
	Small	Increase the distance of spraying.

## 5-2. Maintenance

### **General washing**

- 1) Dispense all liquid entirely from the container, liquid supply hose and dosing parts of the valve.
- 2) Wash the wetted parts inside of the valve with solvent.
- 3) Then run the valve through with air.
- 4) Repeat the solvent → air cleaning method until you are satisfied that the valve is clean.



## Chapter 6. Dimensions

### 6-1 SV2001N

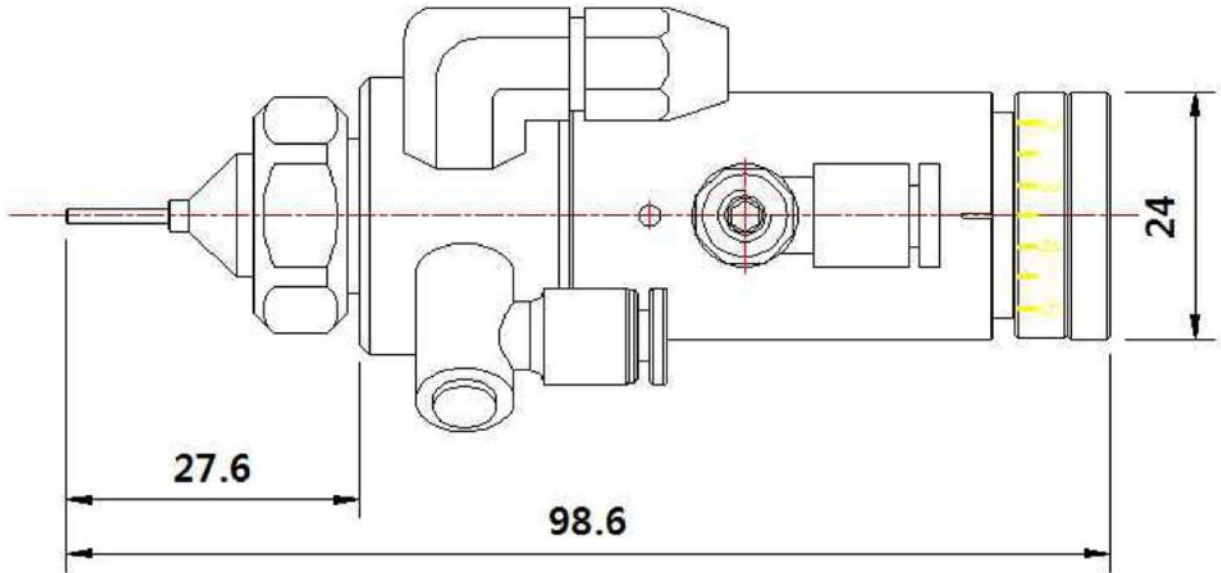

### 6-1 SV2002N

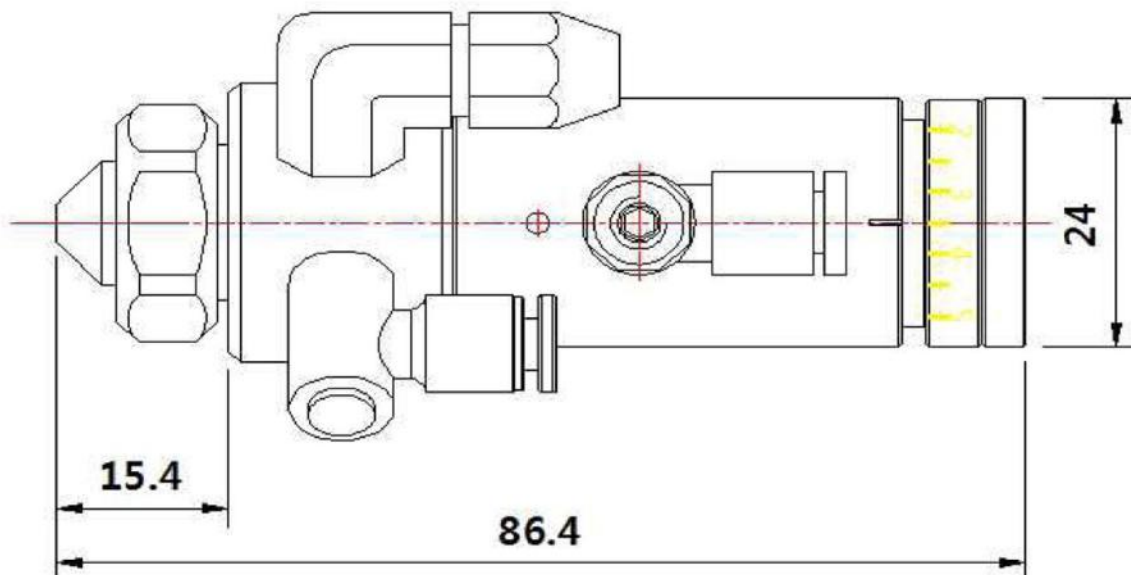

6-1 SV2003N

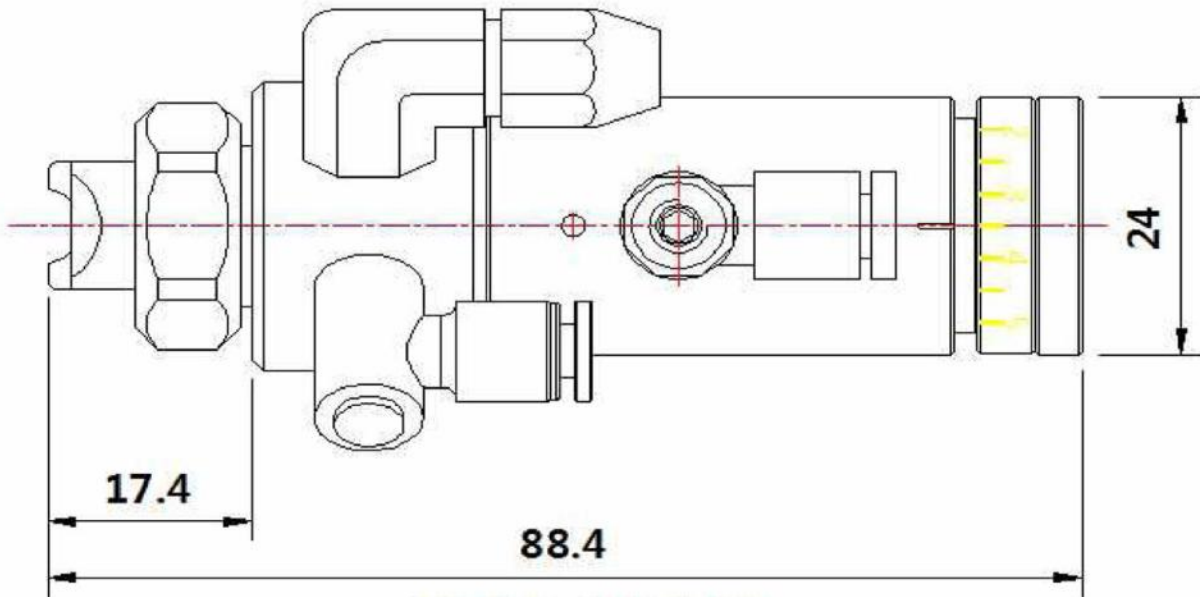

This page intentionally left blank.



15 Corporate Drive, Suite E - Wayne - NJ 07470  
Tel: (973) 646-5044 E-mail: [info@fisnar.com](mailto:info@fisnar.com)  
[www.fisnar.com](http://www.fisnar.com)